

DESCRIPTION AND OPERATION

The Globe Model GL5610 Residential Sprinkler has a low profile yet durable design, which utilizes a 3mm frangible glass ampule as the thermosensitive element. It features economy, aesthetics and low flow.

The combination of the 3mm frangible glass ampule and specially designed deflector makes the Model GL5610 Residential Sprinkler the ultimate in life safety and fire control. This Globe Pendant and Recessed Pendant Residential Sprinkler has met the strict requirements of Underwriters Laboratories Inc. as described in the UL Standard for Residential Sprinklers for Fire Protection Service, UL 1626, and should be used accordingly. This sprinkler should also be installed in accordance with the appropriate NFPA Standard 13, 13D or 13R and under the direction of the approving authorities having jurisdiction.

The heart of Globe's Model GL5610 sprinkler proven actuating assembly is a hermetically sealed frangible glass ampule that contains a precisely measured amount of fluid. When heat is absorbed, the liquid within the bulb expands increasing the internal pressure. At the prescribed temperature, the internal pressure within the ampule exceeds the strength of the glass causing the glass to shatter. This results in water discharge which is distributed in an approved pattern.

The sprinkler and escutcheon are not factory assembled. Assembly is done in the field.

TECHNICAL DATA

- See reverse side for Approvals and Specifications.
- Temperature Rating - 155°F (68°C)
- Water Working Pressure Rating - 175 psi (12 Bars)
- Factory tested hydrostatically to 500 psi (34 Bars)
- Maximum low temperature glass bulb rating is -67°F (-55°C)
- Frame - bronze • Deflector - brass • Screw - brass
- Bulb seat - copper • Spring - nickel alloy • Seal - teflon
- Bulb - glass with alcohol based solution, 3mm size
- Escutcheon Assembly - steel

• SPRINKLER TEMPERATURE RATING/CLASSIFICATION and COLOR CODING

CLASSIFICATION	AVAILABLE SPRINKLER TEMPERATURES		BULB COLOR	N.F.P.A MAXIMUM CEILING TEMPERATURE	
ORDINARY	155°F	68°C	RED	100°F	38°C



**RESIDENTIAL
PENDENT**



**RESIDENTIAL
RECESSED PENDENT**

RESIDENTIAL AUTOMATIC SPRINKLER MODEL GL5610 PENDENT • RECESSED PENDENT

SPECIFICATIONS AND APPROVALS

SIN MODEL	NOMINAL "K" FACTOR	THREAD SIZE	LENGTH	FINISHES	155°F 68°C	cULus
GL5610	5.6 (80 metric)	1/2" NPT	2 1/2" (6.4 cm)	Factory Bronze Bright Chrome Satin Chrome ¹ White Polyester ² Black Polyester ^{1,2} Lead Coated ^{1,2}	X	X

NOTE: METRIC CONVERSIONS ARE APPROXIMATE.

¹ FINISHES AVAILABLE ON SPECIAL ORDER.

² AVAILABLE AS cULus LISTED CORROSION RESISTANT WHEN SPECIFIED ON ORDER.

INSTALLATION DATA FOR FLAT AND SLOPED CEILINGS** PENDENT AND RECESSED PENDENT

MAXIMUM AREA OF COVERAGE	MINIMUM WATER DISCHARGE & PRESSURE NEEDED*
12' X 12'	15 G.P.M - 7.2 P.S.I
14' X 14'	19 G.P.M - 11.5 P.S.I
16' X 16'	19 G.P.M - 11.5 P.S.I
18' X 18'	21 G.P.M - 14.1 P.S.I
20' X 20'	24 G.P.M - 18.4 P.S.I

*WHEN THESE SPRINKLERS ARE USED IN NFPA 13 SYSTEMS, A 0.1 DESIGN DENSITY MINIMUM SHALL BE UTILIZED.

**REFER TO PAGE 2 OF THE GLOBE RESIDENTIAL SPRINKLER INSTALLATION GUIDE FOR NFPA 13D and 13R REQUIREMENTS.

CROSS SECTION

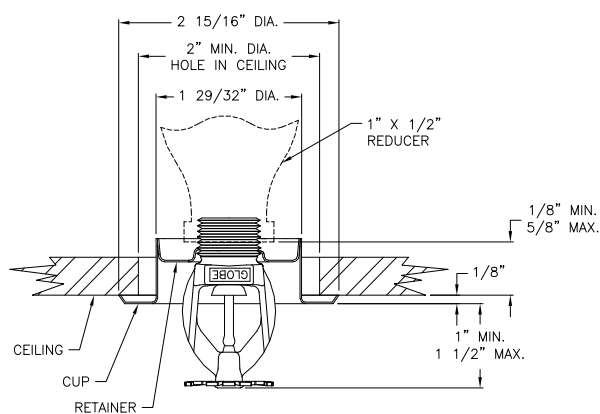

ORDERING INFORMATION SPECIFY

- Quantity • Model Number • Style
- Orifice • Temperature • Finishes desired
- Quantity - Wrenches - P/N 325390
- Quantity - Recessed Wrenches - P/N 325391
- Quantity - Protective Caps - P/N 327109-CAP (Friction Fit Recessed)

GLOBE® PRODUCT WARRANTY

Globe agrees to repair or replace any of its own manufactured products found to be defective in material or workmanship for a period of one year from date of shipment.

For specific details of our warranty please refer to Price List Terms and Conditions of Sale (Our Price List).



4077 AIRPARK DRIVE, STANDISH, MICHIGAN 48658
989-846-4583 FAX 989-846-9231
1-800-248-0278 www.globesprinkler.com