

**SIGHT DRAINS  
 FOR  
 AUTOMATIC  
 SPRINKLER SYSTEMS**

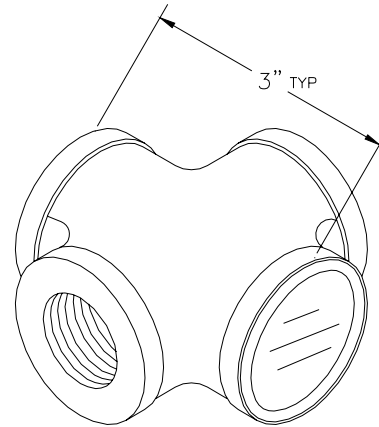

**1" NPT SIGHT DRAIN  
 P/N 323310  
 175 PSI MAXIMUM WWP**

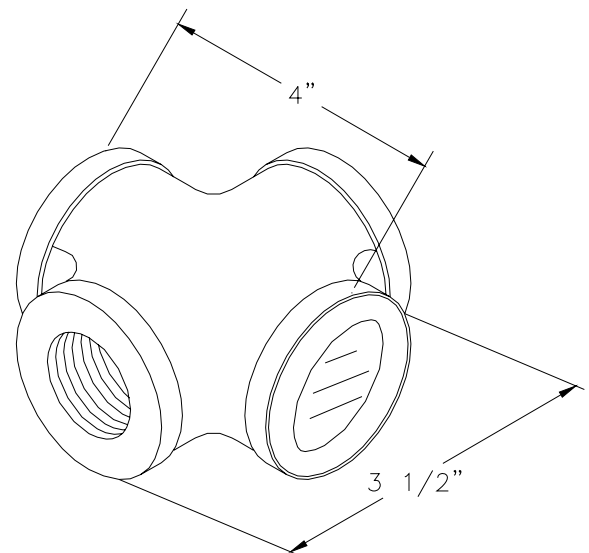

**2" NPT SIGHT DRAIN  
 P/N 323320  
 175 PSI MAXIMUM WWP**